

# GST-FT24N Fire Telephone Panel Installation and Operation Manual

(Issue 1.02 August 2013)



## CONTENTS

<b>1</b>	<b>GENERAL</b> .....	<b>1</b>
<b>2</b>	<b>TECHNICAL SPECIFICATIONS</b> .....	<b>1</b>
<b>3</b>	<b>PANEL INSTRUCTION</b> .....	<b>2</b>
3.1	APPEARANCE AND STRUCTURE .....	2
3.2	THE FRONT SURFACE.....	2
3.3	THE KEYS .....	3
3.4	INDICATORS.....	3
3.5	DIGITRON DISPLAY .....	3
<b>4</b>	<b>FIRE TELEPHONE SYSTEM DESIGN</b> .....	<b>3</b>
4.1	STAND ALONE FIRE TELEPHONE SYSTEM.....	3
4.2	NETWORKED FIRE TELEPHONE SYSTEM.....	4
<b>5</b>	<b>MOUNTING &amp; COMMISSION</b> .....	<b>4</b>
5.1	INITIAL CHECK .....	4
5.2	WIRING REQUIREMENT .....	4
5.3	INSTALLING DIMENSION .....	4
5.4	TERMINALS ON THE PANEL .....	5
5.5	SYSTEM COMMISSIONING .....	5
	<i>Set panel address</i> .....	5
	<i>Register the Network Panels</i> .....	5
	<i>Test Functions</i> .....	5
<b>6</b>	<b>USER GUIDE</b> .....	<b>6</b>
6.1	PANEL CALL HANDSET.....	6
6.2	HANDSET CALL PANEL .....	6
6.3	CALL PANELS IN NETWORK.....	6
6.4	PANEL TO PANEL CALL.....	6
6.5	INQUIRE ABOUT CONVERSATION RECORD .....	6
<b>7</b>	<b>TROUBLESHOOTING</b> .....	<b>6</b>
7.1	ZONE FAULT .....	6
7.2	NETWORK FAULT .....	6

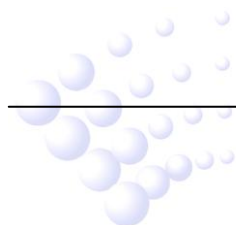

## 1 General

GST-FT24N fire telephone panel is specialized for emergency communication, builds up convenient and prompt 2-way communication in case of fire and other abnormal conditions. It is an indispensable device in fire protection system. The panel has features as below:

- ✧ Standard 3U structure, rack mount installation
- ✧ 24VDC power supply
- ✧ Receiving and calling out with fire telephone handsets
- ✧ Networkable fire telephone panels achieve internal communication
- ✧ Call from handset will be transferred to networked fire telephone panels automatically after not answered by the dedicated panel
- ✧ The handset zones are fully monitored for fault of short circuit and open circuit. Panel will show the fault by sound and indicator.
- ✧ Failure of one zone will not effect on other zones
- ✧ The network communication is monitored. When sub-panel fails to communicate with the main panel, the main panel will get the failure message and broadcast to other networked sub-panels, both main panel and sub-panels will indicate by sound and light indication. When the fault happens on main panel, all sub-panels will show the fault message, and meanwhile the network call will be inhibited.
- ✧ Record: The conversation between fire telephone panel and Handset or other fire telephone panel can be recorded up to 15 minutes. The new content will cover the old one when the storage is full.

## 2 Technical Specifications

Operation Voltage	24VDC $\pm$ 10%
Standby Current	0.2A
Maximum Current	1A
Frequency Range	300~3400Hz
Crosstalk	<-60dB
Transmission Loss	<5dB
Environment Temperature	-5~40°C
Relative Humidity	45%~95%
Dimension	482.5mm $\times$ 132.5mm $\times$ 225mm
Gross Weight	4.2kg
Network Capacity	8 panels
Panel Capacity	24 zones
Zone Capacity	5 handsets
End of Line Resistor	10k $\Omega$ $\pm$ 0.5K $\Omega$

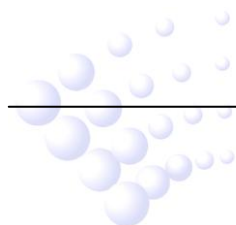

**Notes: words using within this file**

Fire Telephone Panel (Panel): Installed in fire control center, the device can communicate with field terminals, such as GST-FT24N.

Handset: Field device, which can communicate with fire control center, such as P-9911(F) and P-9911(M).

Main panel: The No.1 panel in the fire telephone panel network

Sub-panel: Panels other than No.1 in the fire telephone panel network

### 3 Panel Instruction

#### 3.1 Appearance and Structure

GST-FT24N fire telephone panel is rack mount type, the appearance is shown in Fig.3-1

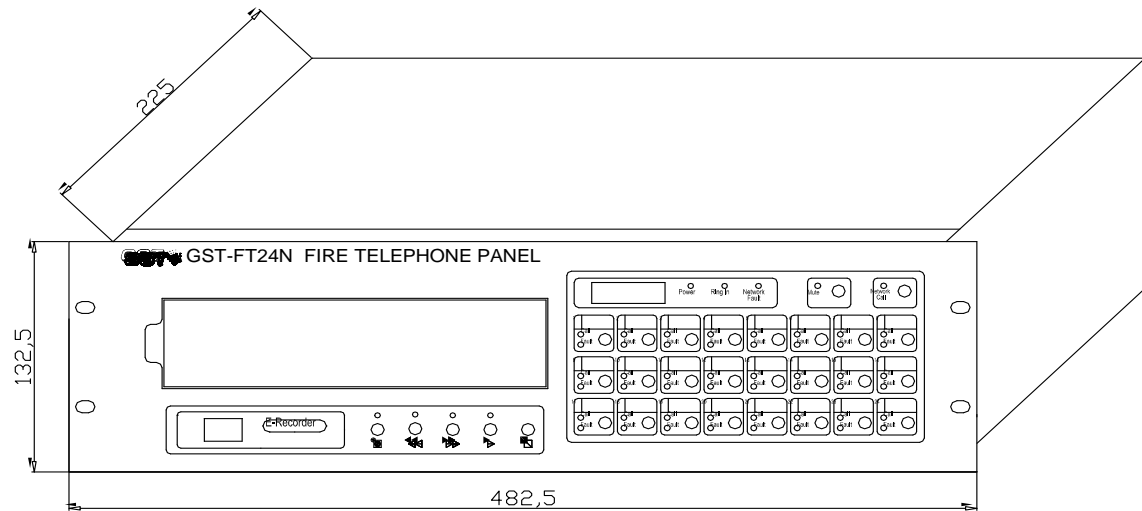

Fig.3-1

#### 3.2 The front surface

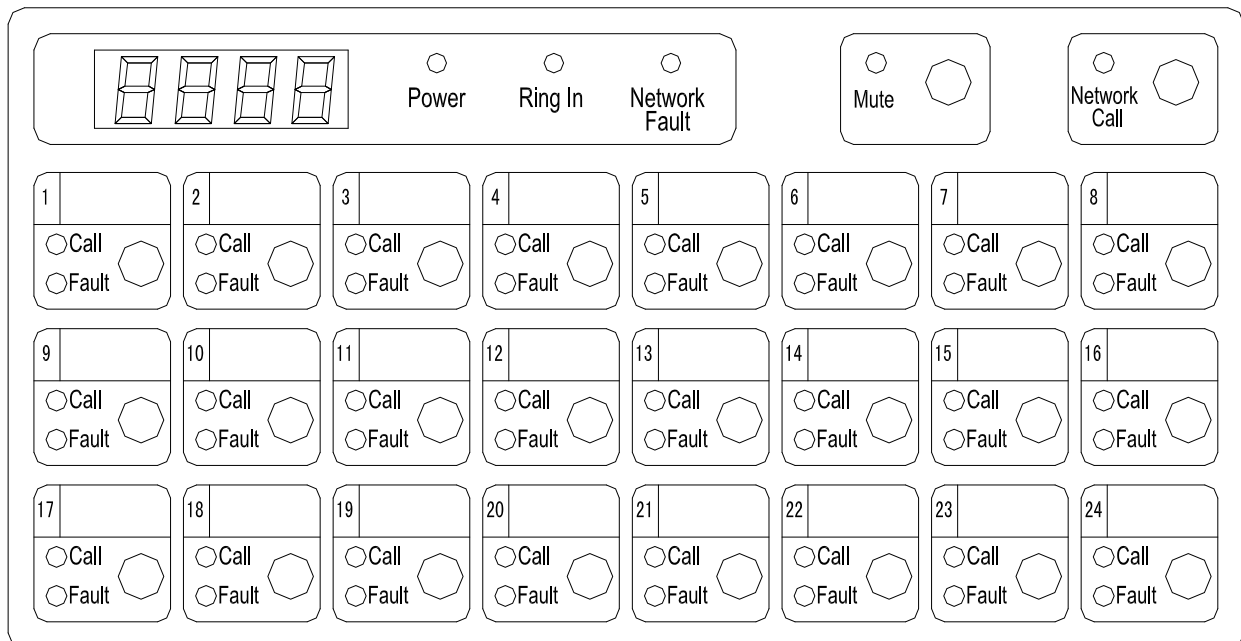

Fig. 3-2

### 3.3 The Keys

Key	Description
“Mute”	Stop the alarm sound caused by fault
“Network Call”	Answer or start network call
Zone 1-24	Answer, call or hang up the corresponding zone.

### 3.4 Indicators

Indicator	Description
“Call” LED, 1-24	Red, indicating the conversation status between panel and corresponding zone. <ul style="list-style-type: none"> <li>➤ Flashing: in the process of connection</li> <li>➤ On: under conversation</li> <li>➤ Off: no conversation</li> </ul>
“Ring In” LED	Red, fast flash when there is call in from network or zone
“Fault” LED, 1-24	Yellow, lit on when corresponding zone in Fault condition
“Network Fault” LED	Yellow, lit on when there is network fault
“Power” LED	Green, lit based on usual power supply
“Mute”	Red, lit when panel sound alarm silenced

### 3.5 Digitron Display

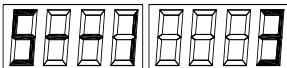
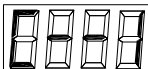
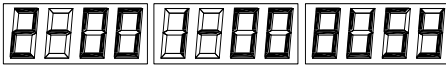
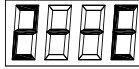
State	Example	Description
Network Free		On the main panel, the first digit indicates the quantity of panels in the network, the last digit indicates its network address On sub-panel, only the last digit will show its network address
Network Call		The first digit indicates the address of the calling panel. The C at the last digit means Calling.
Network Conversation		The sample at the left shows the conversation state between No.1 panel and No.2 panel. The others will show “BUSY”
Network Failure		The first digit indicates the address of failed panel. The E means Error.

## 4 Fire Telephone System Design

### 4.1 Stand Alone Fire Telephone System

Fig. 4-1 shows a standalone fire telephone system. The panel can connect maximum 24 zones with each zone maximum 5 handsets.

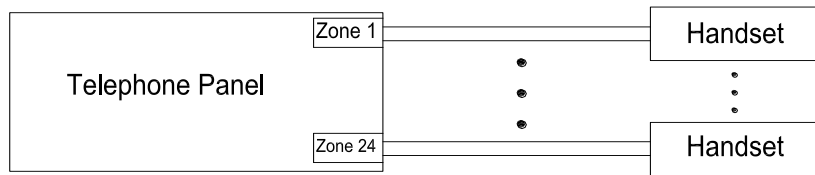

Fig. 4-1

## 4.2 Networked Fire Telephone System

The system consists of a group of panels as many as 8. The panel with the address 1 is the main panel and the rests are sub-panels. Please refer to commission section for setting up addresses.

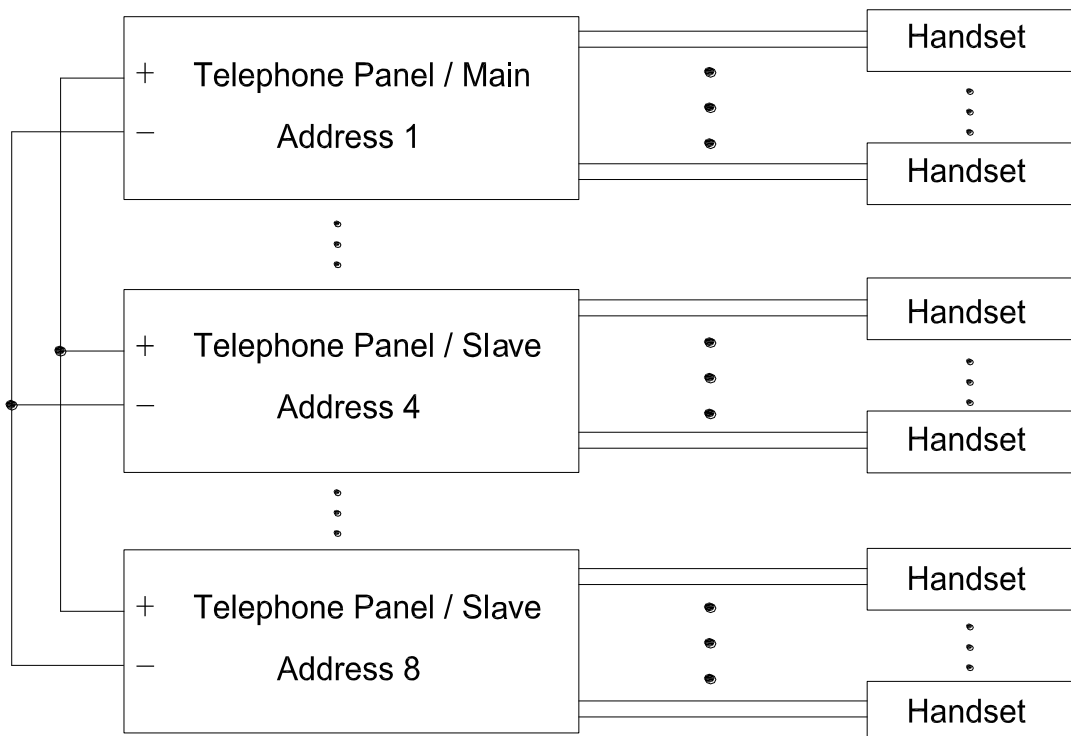

Fig. 4-2

## 5 Mounting & Commission

### 5.1 Initial Check

Check the appearance of the panel after open the box. Then power on and check working state.

### 5.2 Wiring Requirement

- Cross-section area of the power cable not less than 1.5mm<sup>2</sup>
- Twisted-pair cable connecting panel and handset with SA not less than 1.0 mm<sup>2</sup>
- Twisted-pair cable for the network with SA not less than 1.0 mm<sup>2</sup>
- The cable selection must comply with local code

**Note:** the impedance of single line not more than 20Ω

### 5.3 Installing dimension

Installing dimension: 482.5\*132.5\*225mm

## 5.4 Terminals on the panel

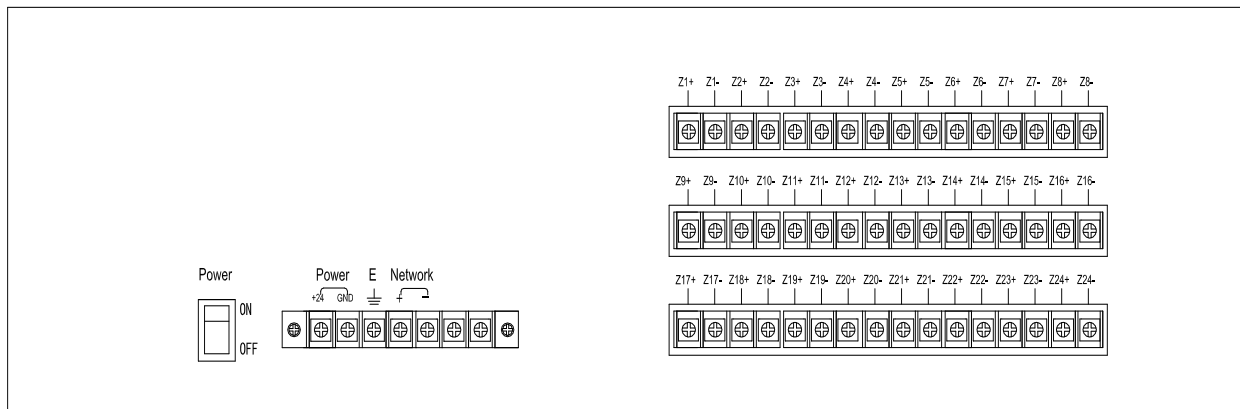

Fig. 5-1

Power (+24, GND): 24VDC power in, polarized

E: GND

Network (+, -): Network, polarized

Audio Output: Audio signal output

Zn+, Zn-: Zone Terminals, connecting with handsets (a 10KΩ±0.5KΩ resistor is required to the last point of each zone).

## 5.5 System Commissioning

**Please Make Sure the Correct Wiring before Commissioning.**

### Set panel address

- For standalone fire telephone system, the address can be assigned 1 or keep the default setting.
- There must be one panel assigned 1 in the network fire telephone system and register other panels.
- Addressing step: Press a key between 1-8 key of front surface, then power on, press the key over 2s, the number will become the network address of the panel. The address will not be lost when the panel is switched off. The address will not be changed unless 1-8 key is pressed when the panel is powered on.

**Note:** The panel addresses can not be repeated in same network.

### Register the Network Panels

After assigning the addresses, power on the sub-panels first. Then power on the main panel. The main panel will register all networked sub-panels automatically. Subsequently, the first digit of the digitron will show the number of networked panels (including the main panel). Check whether all panels have been registered according to the shown number. If no consistency, check the wiring and repeat the above-mentioned process.

The registration information is saved in non-volatile memory, will not loss on power off. The registration should be carried out again in case adding or removing network panels. Not necessary for registration on sub-panel.

### Test Functions

Test the other functions according to Operation Manual after commissioning.

## **6 User Guide**

### **6.1 Panel Call Handset**

Press a key of zone 1 to 24, the corresponded zone will be called with “Call” LED slow-flashing. The conversation will be set when handset picked-up, with “Call” LED lit showing status. During the conversation, press the key again will stop the call. The “call” LED won’t go out until hanging up the handset. If the handset is hung up first, the conversation will stop immediately with “Call” goes out.

The panel can make call to handsets in other zones when a conversation is underway.

### **6.2 Handset Call Panel**

Once the handset is picked up without being called, the call will go to the panel. The panel will ring with “Call” and “Ring In” LED fast-flashing. Press the relative key and enter into conversation with “Call” being on, “Ring In” goes out. Meanwhile, if there are other zones calling panel, “Ring In” will keep fast-flashing. Hang-up the handset or press the relative key on the panel will stop the conversation.

### **6.3 Call Panels in Network**

If the handset call is not answered by the panel within 12s, and the network is available, the call will be transferred to other networked panels. Press “Network Call” and start the conversation. Stop the conversation by handset hanging up or “Network Call” repressed.

### **6.4 Panel to Panel Call**

When network is available, press “Network Call” will send the call to entire network with the LED indicator fast-flashing. Meanwhile, the digitron on other networked panels will show by flashing “C — —X” (X- The calling panel), the “Ring In” and “Network Call” LED will fast flash with ringing sound.

Press “Network Call” button and then start the conversation. The digitron of the panels not attending conversation will show “BUSY” and the ring tone stops. Panel in conversation will show the address of the other one. Either part can stop the conversation by pressing “Network Call”.

### **6.5 Inquire about conversation record**

Press “PLAY” key of the electric recorder, then the record will be played. Press “FORWARD” and “REWIND” to switch the content rapidly and press “■” to stop. Electric recorder will start or stop recording automatically along with the conversation, The new content will cover the old one when the storage is full.

## **7 Troubleshooting**

### **7.1 Zone Fault**

The zone fault shows an open or short circuit between panel and handsets, or the End of Line Resistor not connected. Check the cable by multi-meter, whether the resistance is roughly 10kΩ.

### **7.2 Network Fault**

The panel shows network fault when there is any of the panels powered off or network cable fault. Check the malfunction panel and wiring.

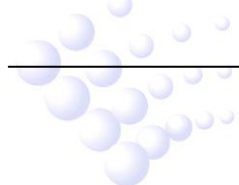





Gulf Security Technology Co., Ltd.

No. 80, Changjiang East Road, QETDZ, Qinhuangdao, Hebei,

P. R. China 066004

Tel: +86 (0) 335 8502434

Fax: +86 (0) 335 8502532

[service.gst@fs.utc.com](mailto:service.gst@fs.utc.com)

[www.gst.com.cn](http://www.gst.com.cn)