



DI-9204Exd
Digital Flame-proof Manual Call Point



Installation and Operation Manual

Issue 1.03 August 2012
ERP:30304872

CONTENTS

1 General	1
2 Features	1
3 Technical Specifications	1
4 Construction and Operation Principle	2
4.1 Exterior View	2
4.2 Operation Principle.....	2
5 Installation and Wiring	2
5.1 Wall-mounting	2
5.2 Pole-mounting	4
6 Testing	5
7 Operation	6
8 Applications	6
8.1 Application in Addressable Mode	6
8.2 Non-addressable Mode.....	6
8.3 Application in Supervised Digital Input (SDI) Loop	7
9 Troubleshooting and Maintenance	7
10 Caution	7
11 Accessories and Tools	7

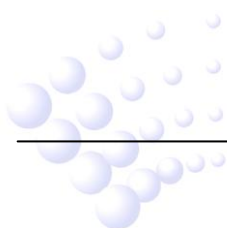

1 General

DI-9204Exd Digital Flame-proof Manual Call Point (MCP) is installed in vessels and industrial explosion-proof areas. When there is fire, pressing the glass on this MCP, alarm signal can be sent to fire alarm control panel (FACP).

The MCP can work at addressable mode to connect with GST's series FACP that can control fire suppression devices and transmit signal through loop. It can also work at non-addressable mode to connect with 24VDC power and output fire alarm signal through key switch.

The MCP is applicable to vessels, Zone 1 and 2 of explosive gas atmosphere and Zone 20, 21, and 22 of explosive dust atmosphere. It is also suitable for outdoor application.

2 Features

- ✧ Using built-in microprocessor for alarm detection and output control. It features stable operation and good protection against electromagnetic interference.
- ✧ Electronically addressed. The address can be modified in field.
- ✧ An independent output contact is provided to control periphery devices.
- ✧ The MCP is reusable. You can press it to alarm, and reset it by a special key.
- ✧ With wide temperature range, high ingress protection rating, the MCP can apply to vessels, outdoors and explosive hazardous environment.

3 Technical Specifications

- ✧ Operating Voltage:
 - Addressable Mode: Loop 24V, ranged 16V~28V
 - Non-addressable Mode: 24VDC, ranged 20VDC~28VDC
- ✧ Operating Current: Standby Current $\leq 0.8\text{mA}$
Alarm Current $\leq 2.5\text{mA}$
- ✧ Output Capacity: normally open volt-free output, contact capacity is 1A 24VDC
- ✧ Type of Initiating Part: Reusable.
- ✧ Initiating Mode: Pressing the glass manually.
- ✧ Resuming Mode: Manually resuming the MCP by a special key.
- ✧ Fire Indicator: Red. It flashes normally and lights after alarming.
- ✧ Address Programming Method: Electronic programming (Address is within 1~242)
- ✧ Operating Environment: Temperature: $-40^{\circ}\text{C} \sim +70^{\circ}\text{C}$
Relative Humidity $\leq 95\%$
- ✧ Dimensions: 211mm \times 129mm \times 95mm (without accessories)
- ✧ Ingress Protection Rating: IP65
- ✧ Material and Color of the Enclosure: ZL102 aluminum alloy, red
- ✧ Weight: 2kg
- ✧ Mounting Hole Distance: 163mm
- ✧ Explosion-proof marking: Exd II BT6 Gb/DIP A20 TA, T6
- ✧ Explosion-proof Certificate No. : CE12.1341

4 Construction and Operation Principle

4.1 Exterior View

The exterior view of the MCP is shown in Fig. 1.

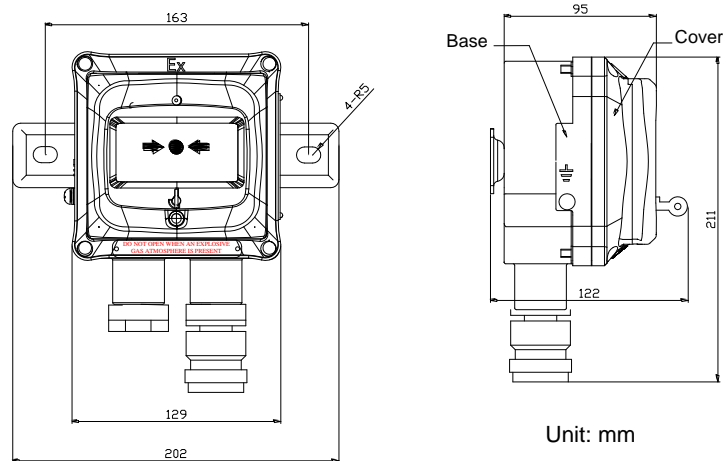

Fig. 1

4.2 Operation Principle

The MCP alarms fire if pressed. It is self-locked mechanically to reduce possibility of mis-triggered alarm. The built-in microprocessor is designed for checking alarms and controlling its indicators.

5 Installation and Wiring

Warning: Before installing the MCP, disconnect power from the loop.

Before installation, check whether the enclosure and labels are sound and complete.

The MCP can be installed either on the wall or on a pole.

5.1 Wall-mounting

The schematic diagram for a wall-mounted MCP is shown in Fig. 2.

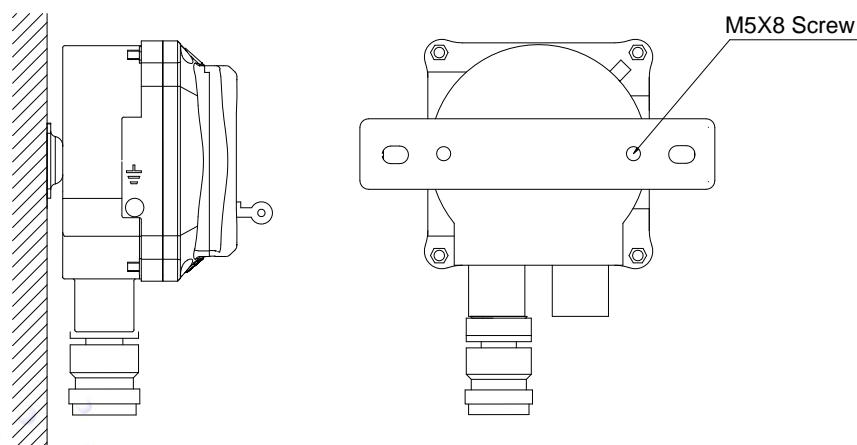

Fig. 2

The steps for installing the MCP on the wall are as follows.

5.1.1 Installation of Base and Mounting Plate

The MCP consists of a base and an enclosure. Before installation, unfasten the four screws and remove the enclosure from the base with care.

Connect the mounting plate and base with M5×8 cross recessed countersunk pan head screws. Then fasten them to the wall with M8×60 expansion bolts.

5.1.2 Cabling

For MCPs with explosion mark Ex dII B T6 Gb, the cables are to be drawn in through grommets. Thread the screened twisted pair with cross section not less than 1.0mm² and outer diameter φ 8mm-φ 10mm through a metal washer and a grommet, screw them all into the MCP enclosure, and then tighten the grommet with the thread using an Allen key.

For MCPs with explosion-proof mark Ex dII C T6 Gb, the cables are to be drawn in through flame-proof cable glands following the steps below:

- Strip an armored cable with cross section not less than 1.0mm² and outer diameter φ 8mm as shown in Fig. 3.
- Install the “Entrance Interface 3” and “Grommet 1” to the MCP body using an Allen key.
- Thread the end of cable through “Nut 8”, “Grommet 7”, “Middle Sheath 4”, “Outer Washer 6”, “Taper Washer 5”, and “Flame-proof Washer 9” in sequence, and put the “Inner Sheath” of the cable inside the “Flame-proof Washer 9” of the gland, cover the “Armor Layer” of the cable outside the “Taper Washer 5” of the gland, and then add the “Outer Washer 6” of the gland.
- Fill the uniformly mixed sealing filler between “Flame-proof Washer 9” and “Taper Washer 5”, and then press the two parts tightly. Screw “Middle Sheath 4” onto “Entrance Interface 3” securely. Refer to Fig. 4.
- Finally screw and lock “Nut 8” onto “Middle Sheath 4”, as shown in Fig. 4.

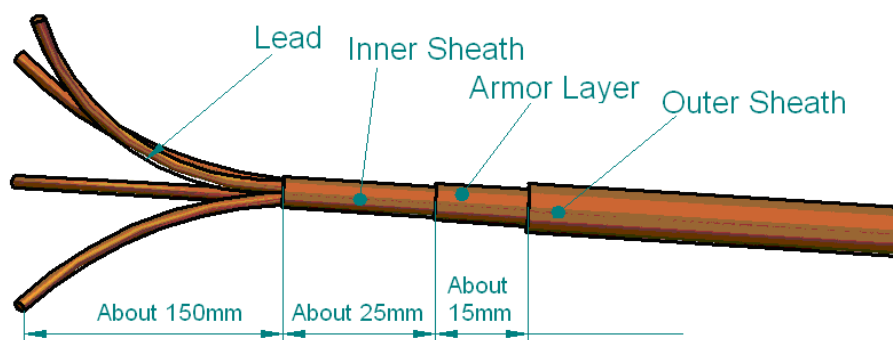
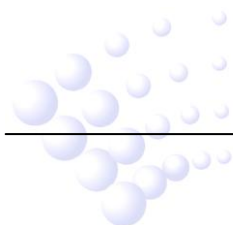
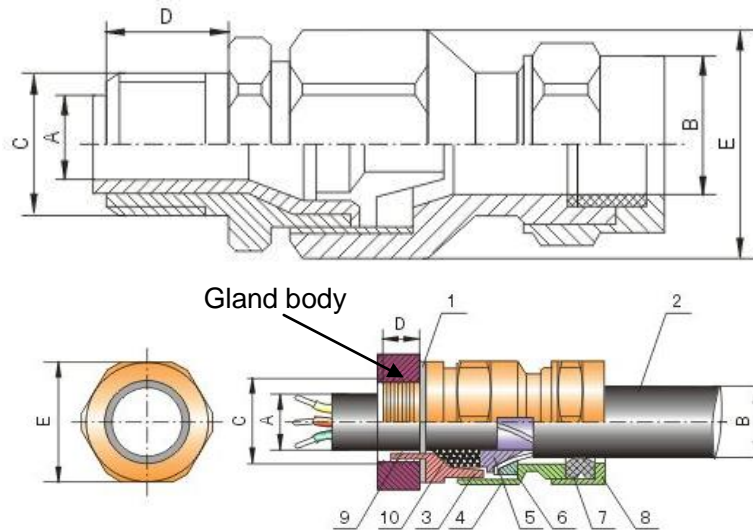

Fig. 3





1. Grommet 2. Armored Cable 3. Entrance Interface 4. Middle Sheath 5. Taper Washer
6. Outer Washer 7. Grommet 8. Nut 9. Flame-proof Washer 10. Sealing Filler

Fig. 4

5.1.3 Connection

There are terminals on the circuit board in the cover, as shown in Fig. 5.

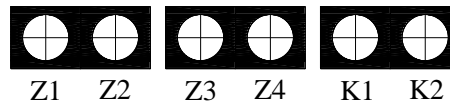

Fig. 5

Terminal description:

Z1, Z2: In addressable mode, connecting with signal cable, polarity-insensitive. In non-addressable mode, connecting with 24VDC, polarity-insensitive.

Z3, Z4: Junction output for input signal of Z1 and Z2.

K1, K2: Volt free normally open output terminals. When the MCP is pressed, output contact is closed to control external devices. These two terminals are optional that can be used or not.

Connect the cables to the terminals in sequence.

(4) Final installation

After connection, put the cover into the base, and then fasten them with M5x10 Hexagon socket countersunk head screws.

5.2 Pole-mounting

The pole-mounted MCP is shown in Fig. 6 and dimension of the pole is shown in Fig. 7.

The mounting steps is as follows:

- (1) Thread the cable through the cable outlet of the pole and the rubber washer.
- (2) Install the pole on the ground using M10 anchor bolts.
- (3) Screw down the cover, and lay out the cables according to the application requirement with the same method as wall-mounting.
- (4) Wire the MCP with the same method as wall-mounting.
- (5) Connect the MCP base with the pole using M4X10 screw assembly.
- (6) Install the MCP with the same method as wall-mounting.

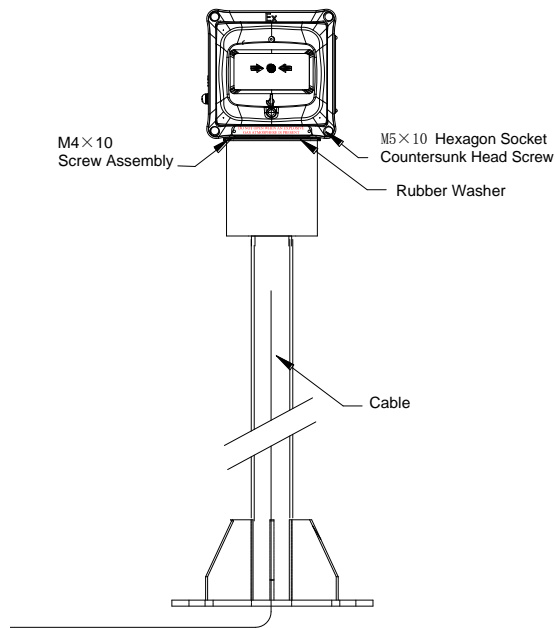

Fig. 6

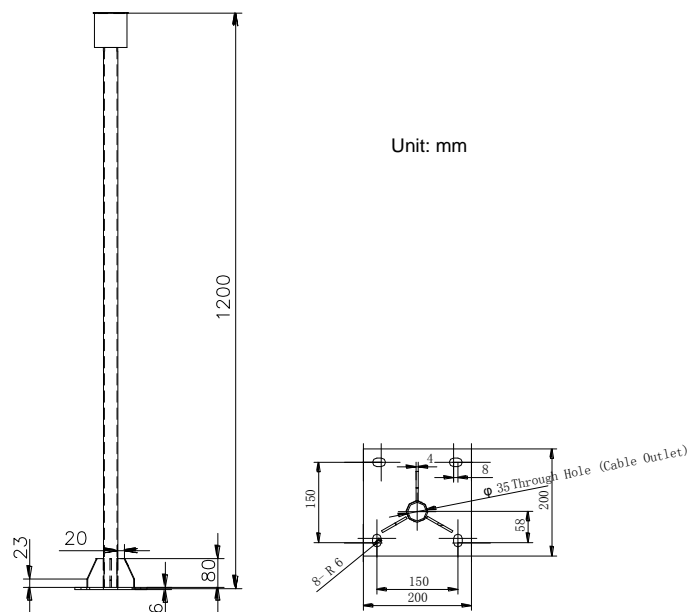

Fig. 7

6 Testing

Warning: Power up only after all the devices are well connected.

- (1) Test the MCP after installation or regular maintenance.
- (2) Before testing, notify the proper authorities that the system is undergoing maintenance and will temporarily be out of service. Disable the zone or system undergoing maintenance to avoid unwanted alarms.
- (3) Testing in addressable mode: Pressing the glass, the red alarm indicator shall constantly illuminate, and the FACP shall display the MCP address.

- (4) Testing in Non-addressable Mode: Pressing the glass, the red alarm indicator shall constantly illuminate, and the output contacts K1 and K2 shall be shorted.
- (5) After testing, reset the MCP by the special key. Notify the proper authorities the system is back in operation. If the MCP fails, check if its connection is correct and retest it. If it still fails, please return it for repair.

7 Operation

- (1) If the MCP works in addressable mode, it needs to be programmed with an address ranging from 1 to 242 using GST handheld programmer. Please refer to the installation and operation manual of the programmer.
- (2) Please reset the MCP if the fire alarm is cleared.

8 Applications

8.1 Application in Addressable Mode

In addressable mode, connect terminal Z1 and Z2 with the loop of the FACP. K1 and K2 can be used as the input signal for other fire protection devices, as shown in Fig. 8.

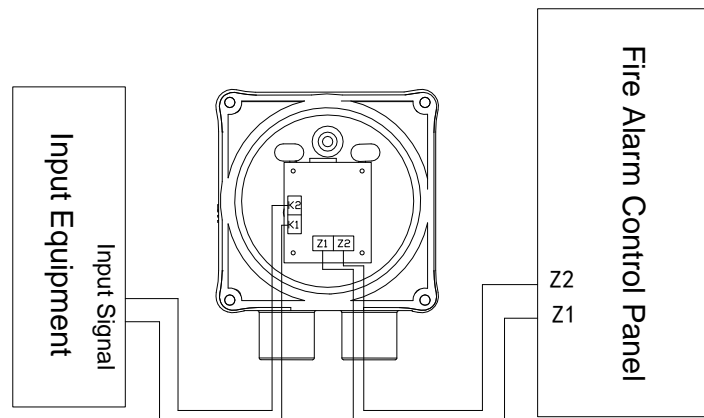

Fig. 8

8.2 Non-addressable Mode

When the MCP works in non-addressable mode, connect Z1 and Z2 with 24VDC, and K1, K2 as the input signal for other fire protection devices, as shown in Fig. 9.

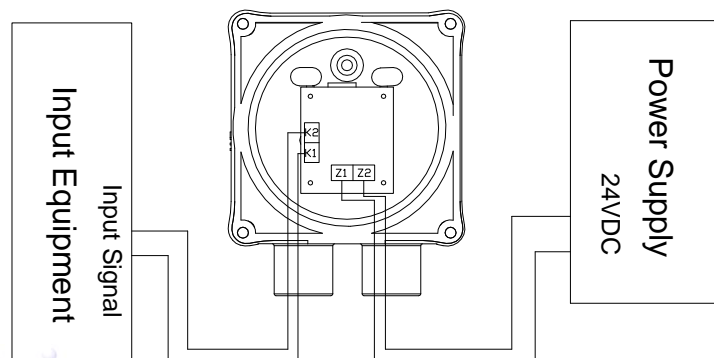

Fig. 9

8.3 Application in Supervised Digital Input (SDI) Loop

The MCP can also be used in SDI loop, as in Fig. 10, in which the 2.5k resistor is connected between Z1 and Z2, and the 1k resistor is connected between K2 and Z1.

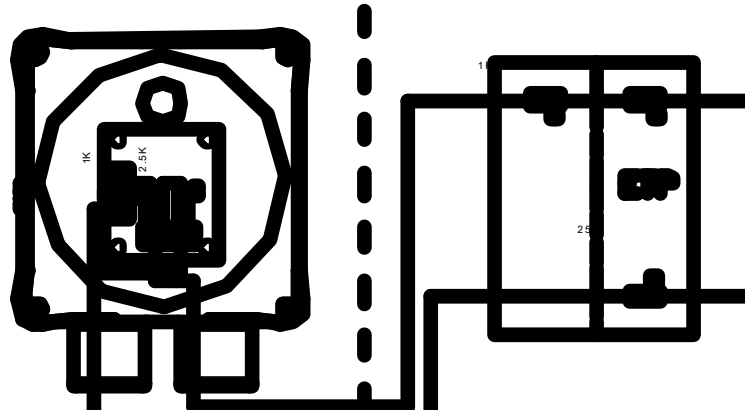

Fig. 10

9 Troubleshooting and Maintenance

(1) Cannot be programmed

If the MCP cannot be programmed, please check the programmer and connecting terminals. Otherwise, the circuit may be broken.

(2) Cannot be registered

If the MCP cannot be registered, please check whether the wiring of the bus is correct, voltage within normal range and the MCP plugged firmly. Otherwise, the circuit may be broken.

10 Caution

(1) Install and maintain the MCP in compliance with installation code applied to explosive hazardous areas.

(2) It is prohibited to open the cover with power on in field.

(3) The enclosure should be earthed.

11 Accessories and Tools

◇ Expansion bolt M8 × 60	2
◇ Screw M5 × 8	2
◇ Washer Φ 5	2
◇ Spring washer Φ 5	2
◇ Mounting plate	1
◇ Reset key	1
◇ 1k resistor	1
◇ 2.5k resistor	1
◇ M5 Allen Key	1



Gulf Security Technology Co., Ltd.

No. 80, Changjiang East Road, QETDZ, Qinhuangdao, Hebei,
P. R. China 066004

Tel: +86 (0) 335 8502434

Fax: +86 (0) 335 8502532

service.gst@fs.utc.com

www.gst.com.cn