

Features

- ✧ Electronically addressed. The address can be modified in field.
- ✧ Alarming by pressing. Reset by a special key.
- ✧ Plug-in structure.
- ✧ Designed to comply with EN 54-11.

Description

Connecting to the loop of GST fire alarm system, DI-9204 Digital Manual Call Point (the MCP) is suitable for public places. When there is fire, pressing the action plate on the MCP can send the alarm signal to fire alarm control panel. After receiving the signal, the control panel will show address information of the MCP and generate alarm sound.

Connection and Cabling

Terminals on the MCP base are shown as Fig. 1.

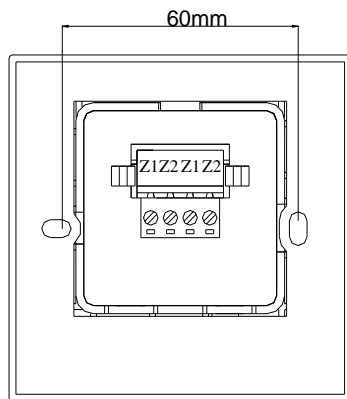

Fig. 1

Z1, Z2: Connecting to the loop of control panel, polarity-insensitive.

Recommended Cabling

0.5mm² or above fire cable, subject to local codes.

Installation

The conduit can be surface mounted or flush mounted.

Surface mounting:

First install the back box onto the wall using 4 screws, and then install the base onto the back box. Connect cables to corresponding terminals as described above. Hook the juts of the MCP body to the base, and then press the part below the action plate to combine them completely. Fig. 2 shows surface mounting.

Flush mounting:

Install the base into the back box. Then combine the enclosure and base the same as surface mounting. Fig. 3 shows flush mounting.

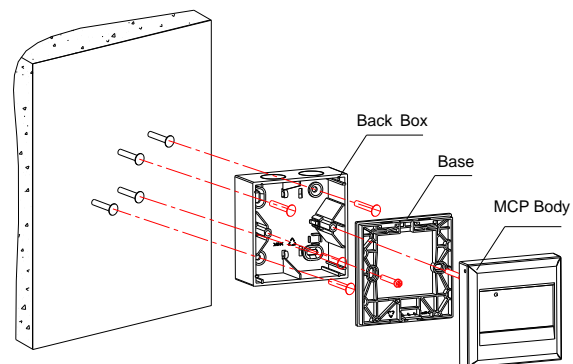

Fig. 2

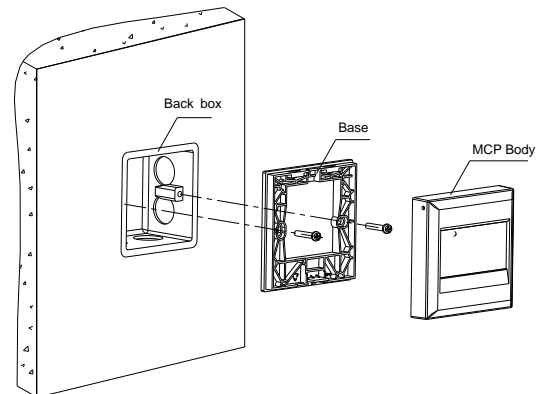

Fig. 3

Application

- ✧ The MCP should be programmed using P-9910B programmer. Please refer to *P-9910B Hand Held Programmer Installation and Operation Manual*.
 - ✧ Terminal Z1 and Z2 of MCP base can directly connect to the loop of control panel. After correct connection, the control panel should be able to register the MCP.
 - ✧ Usage of the key
- Vertically insert the key into the key-hole, then push it with force and turn it clockwise. Turn the key back and pull it out when the action plate is rebounded.
- ✧ Usage of the test tool

The test tool is used to keep continuity during commissioning or maintenance when MCP is not installed, so that cable test can be carried out easily and make the circuit completed.

✧ Compatible Equipment

This MCP can be used together with control panels such as GST100, GST200, GST5000 and GST9000.

Accessories and Tools

Model	Name	Remark
P-9910B	Hand Held Programmer	Order separately

Limited Warranty

GST warrants that the product will be free of charge for repairing or replacing from defects in design, materials and workmanship during the warranty period.

This warranty doesn't cover any product that is found to have been improperly installed or used in any way not in accordance with the instructions supplied with the product. Anybody, including the agents, distributors or employees, is not in the position to amend the contents of this warranty. Please contact your local distributor for products not covered by this warranty.

Specification

Operating Voltage	Loop 24V (16V~28V)
Standby Current	≤0.6mA
Alarm Current	≤1.8mA
Indicator	Red. Flashes once three seconds. Illuminates after alarming.
Type of Initiating Part	Reusable
Initiating Mode	Pressing the action plate manually
Resuming Mode	Manually resumed by a special key
Programming Mode	Electronically addressed
Code Range	One address within 1~242
Wiring	Two-wire, polarity-insensitive
Class	Type A, indoor use
Ingress Protection Rating	IP43
Ambient Temperature	-10℃~+55℃
Relative Humidity	≤95%, non condensing
Material of Enclosure	ABS
Dimension (L×W×H)	87.1mm×87.1mm×58mm (with back box) 87.1mm×87.1mm×23mm (without back box)
Mounting Hole Distance	60mm
Weight	About 160g (with back box) About 107g (without back box)

This Data Sheet is subject to change without notice. Please contact GST for more information or questions.

Gulf Security Technology Co., Ltd.

No. 80, Changjiang East Road, QETDZ, Qinhuangdao, Hebei, P. R. China 066004

Tel: +86 (0) 335 8502434 Fax: +86 (0) 335 8502532

service.gst@fs.utc.com www.gst.com.cn